



®made in Poland

UV WATER AND AIR STERILIZERS

TMA 15-592 BIAŁYSTOK BIAŁOSTOCZEK 26 GM. ZABŁUDÓW	Series	AMX SERIES WATER STERILIZER	TEL 85 743 12 46 TEL 85 687 14 50 www.tma.pl , www.tma.com.pl e-mail: biuro@tma.pl
	Type	STERILIZER AMX 0	

TECHNICAL SPECIFICATION:			
Material		Stainless steel	
Finish		Polished (Ra<0,8um)	
Dimensions	X / Y / Z	[mm]	130 x 245 x 1690
	L / L1	[mm]	1464 x 71
	DN / D	[mm]	R 3" / 130
Chamber Safety Class		IP 66	
Maximal Pressure		10 bar	
Operating Temperature		0,5 - 50 °C	
Turbolizer ¹		Yes	
Quartz Sleeve Guide		Yes / 1 pcs	
Optical UV Lamp Work Indicator		Yes / 1 pcs	
Drain Plug		Yes	
Sample Valve		Yes	
Working Orientation		Horizontal	

CONTROLS:	
Power Supply	~220V-240V 50/60Hz
Nominal Power	360 W
Number	1 pcs
Material	ABS
Enclosure colour	RAL 7035
Dimensions a / b / c	[mm] 325x250x120
Enclosure Safety Class	IP 65
Electronic Ballasts Safety Class	IP 66
Remote-controlled on/off Switch	Yes
Alarm System	Yes
Audible UV Lamp Fault Alarm	Yes
Optical UV Lamp Fault Indicator	Yes
Optical Power Indicator	Yes
Remaining Work Days Counter	Yes
Working Hours Counter	Yes
Number Of Switches Counter	Yes
Solenoid Valve Terminal	Yes
Alarm Signal Output	Yes

LOW PRESSURE UV LAMPS:	
UV Lamp Type	AMX
Number Of UV Lamps – Low Pressure	1 / amalgam
UV Lamp Power	325 W
Life of UV Lamp	16 000 h
UVC Radiation Power	110 W UVC/ 1 pcs

NOMINAL EFFICIENCY:	
Nominal Flow at transmittance T ₁₀ =95%, dose 400J/m ²	28,0 m³/h

Weight With Controls	17 kg
----------------------	-------

OPTIONS (ON REQUEST / EXTRA CHARGE):

- External / internal Polishing (Ra<0,1um)
- Changing Flange Connection
- Changing The Orientation Of Inlet /Outlet
- Chamber Made For Pressure 16 Bar
- Electrical Enclosure made from Stainless Steel
- Digital UV Intensity Measurement System

Assembly and exchange of quartz sleeve and UV lamp without tools. Exchange of UV lamp without unsealing of the system.

¹It provides the same effectiveness of the UV radiation throughout the chamber. This increases the effective dose of UV radiation.
 ALL DIMENSIONS REFER TO THE STANDARD VERSION TO OPERATE AT A PRESSURE OF 10 BAR [PN10]. IN ANOTHER VERSION, THE SIZE MAY VARY SLIGHTLY.
 TMA COMPANY RESERVES THE RIGHTS TO CHANGE CONSTRUCTION WITHOUT NOTICE.



®made in Poland

UV WATER AND AIR STERILIZERS

DIMENSIONAL DRAWING

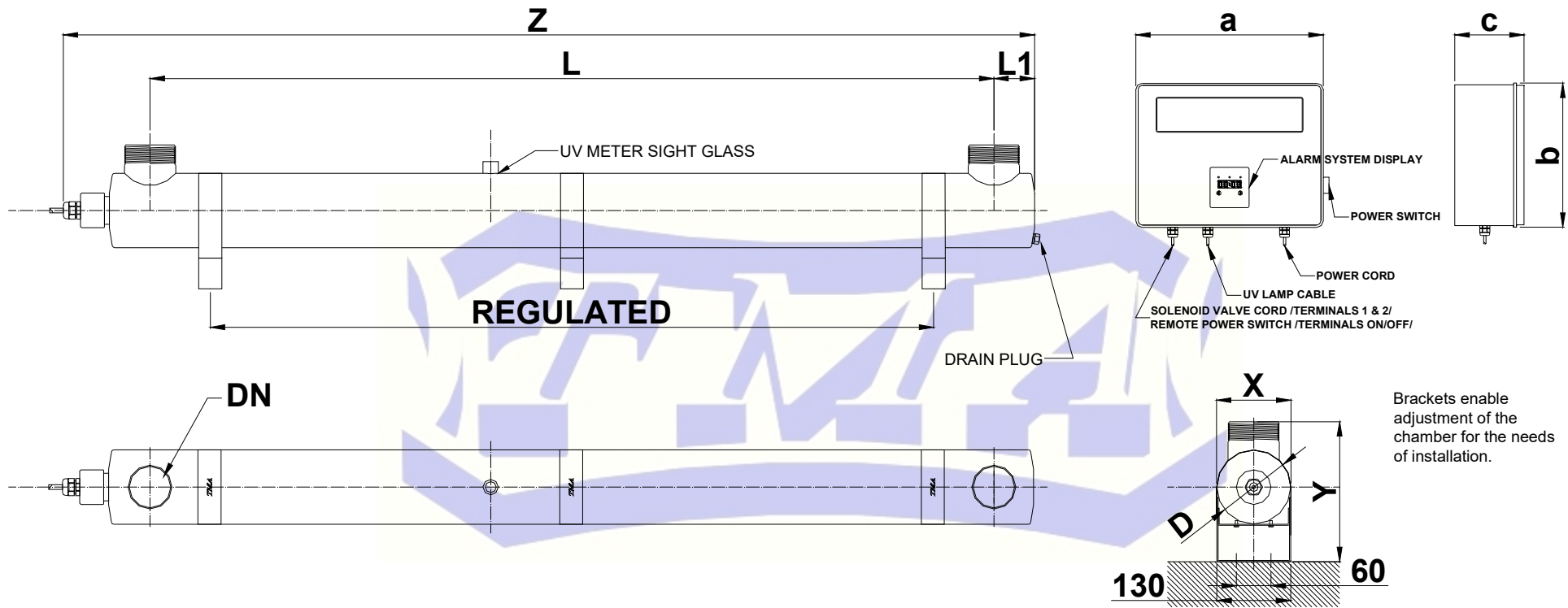

STERILIZER MODEL	X [mm]	Y [mm]	Z [mm]	D [mm]	DN	L [mm]	L1 [mm]	a [mm]	b [mm]	c [mm]
AMX 0	130	245	1690	130	R 3" (DN80)	1464	71	325	250	120 (with UV Meter -160)

ALL DIMENSIONS REFER TO THE STANDARD VERSION TO OPERATE AT A PRESSURE OF 10 BAR [PN10]. IN ANOTHER VERSION, THE SIZE MAY VARY SLIGHTLY.
TMA COMPANY RESERVES THE RIGHTS TO CHANGE CONSTRUCTION WITHOUT NOTICE.